

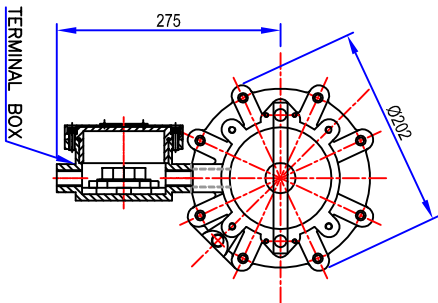

TORQUE RATINGS & DIMENSION DETAILS FOR FLP-WP-ELECTRO-HYDRAULIC THRUSTORS BRAKES.

BRAKE TYPE	DRUM DIA. (MM.)	THRUSTOR TYPE	INPUT WATTS	CURRENT DRAWN (AMP)	THRUSTOR CAP. (KGS.)	THRUSTOR STROKE (MM.)	BRAKING TORQUE (KGM.)	A	B	C	N	E	F	G	h	H	I	J	K	L	M	WT. OF BRAKE
<i>Suni-FMDT10018</i>	100	<i>Suni-FST 520</i>	90	0.25	18	50	6	300	130	70	20	-	160	90	125	470	6	120	90	405	14	15
<i>Suni-FMDT15018</i>	150	<i>Suni-FST 520</i>	90	0.25	18	50	9	330	160	70	20	-	130	120	125	470	6	120	90	465	14	15
<i>Suni-FMDT16018</i>	160	<i>Suni-FST 520</i>	90	0.25	18	50	20	360	200	88	20	362	-	163	200	580	6	150	110	565	14	18
<i>Suni-FMDT20018</i>	200	<i>Suni-FST 520</i>	90	0.25	18	50	32	360	200	88	20	362	-	163	200	580	6	150	110	565	14	18
<i>Suni-FMDT20034</i>	200	<i>Suni-FST 535</i>	150	0.45	34	50	35	385	225	100	20	412	112	188	225	490	6	150	110	640	14	20
<i>Suni-FMDT25018</i>	250	<i>Suni-FST 520</i>	90	0.25	18	50	42	408	225	100	20	412	112	188	225	580	6	150	110	640	14	20
<i>Suni-FMDT25034</i>	250	<i>Suni-FST 535</i>	150	0.45	34	50	62	440	270	140	25	455	115	225	275	600	8	168	130	730	19	33
<i>Suni-FMDT30034</i>	300	<i>Suni-FST 546</i>	160	0.60	46	50	70	440	270	140	25	455	115	225	275	600	8	168	130	730	19	33
<i>Suni-FMDT40034</i>	400	<i>Suni-FST 535</i>	150	0.45	34	50	90	510	360	165	35	510	110	290	310	630	8	198	145	870	19	53
<i>Suni-FMDT40046</i>	400	<i>Suni-FST 546</i>	160	0.60	46	50	110	510	360	165	35	510	110	290	310	630	8	198	145	870	19	53



CIM/FR CRT.No.		CIM/FR/TC/PI/294		Date-25-4-2017 / CIM/FR/TC/S/5408		DATE-01-01-2018	
CCE No.		A/P/HQ/MH/104/6044 (P411322/1)		DATE-26/11/2018			
BIS No.		CM/L/7800028013		DATED- 27-09-2017			
DRN.		PRAKASH		27/03/16		SCALE	
CHD.		G.G.YADAV		27/03/16		MATL.	
APPD.		G.G.YADAV		27/03/16		TYPE NO.	
						AS PER CHART	
						N.T.S.	
						AL./CL./M.S.	
TITLE.		ALL DIMENSIONS ARE IN MM.		TOL - OVERALL DIM ±5MM.		BOLTING CENTER ±3MM.	
DRG. NO.		<i>Suni /GA/ FLP-Thrustor-JIC-1001/07</i>		REV - 0			

Suni® Cranes Controls
AN ISO 9001:2015 CERTIFIED COMPANY



सुनी क्रेन्स कंट्रोल
एन आर एन सी २००१:२०१५ प्रमाणित कंपनी

Shubh Indl. Estate Vasu(e) PALGHAR-401208